

ProLevel v2

Software for Optimum Surface Measurements





ProLevel v2

You have made a good choice ...

ProLevel v2, in combination with the display unit, provides optimum documentation of surface measurements.

The following functions and characteristics will convince you:

- Excellent user interface: logical and user-friendly and nevertheless fully suitable for professional use.
- Automatic connection management, wireless via Bluetooth.
- Automatic sensor detection.
- Measuring point comments can be inserted and edited.
- Easy-to-use touch screen, no keyboard needed.
- Reports and measured data can be stored on USB stick.
- Automatic calculation of the best reference.
- High-performance display unit is robust and yet lightweight.

Contents

Preparatory laser alignment for optimum surface measurements	3
The software – first steps	4 ff
Register new sensors – license key	10
Descriptions of the program symbols	11
DU310 UMPC	12
Accessories for DU310 UMPC	13
Rotation laser T310	14
Sensor R310	15
Sensor R525	15

Preparatory laser alignment for optimum surface measurements

1. Set up the T310 rotation laser in the direction of measurement.

Use the integrated spirit level to align the housing so that it is perpendicular.

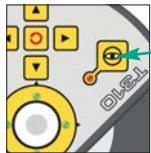

2. Now switch on the leveling function of the T310.



3. Now adjust the height of the tripod so that the laser beam strikes the middle measuring range of the receiver positioned on the measuring point.

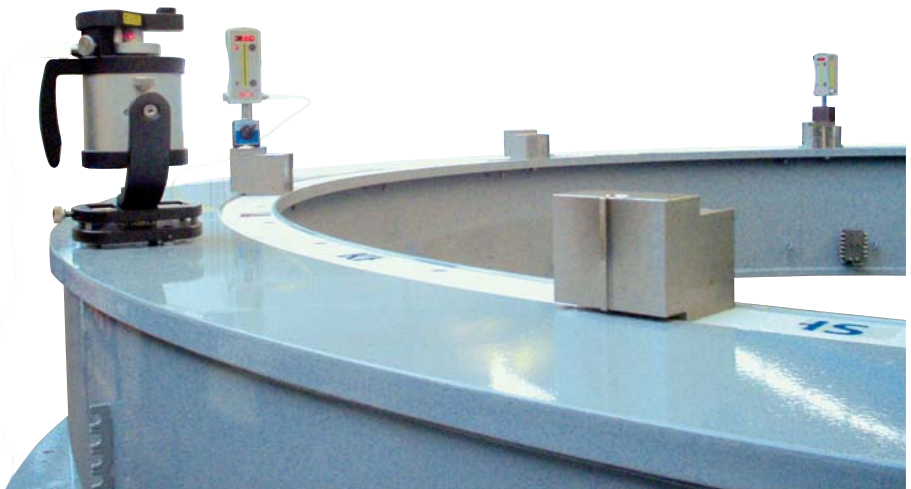

The software – first steps

Switch the sensor on and open the target window.

For instructions for preparatory laser alignment, see page 3.

Start the ProLevel v2 software via the desktop icon .

The software automatically establishes a connection to the sensor.

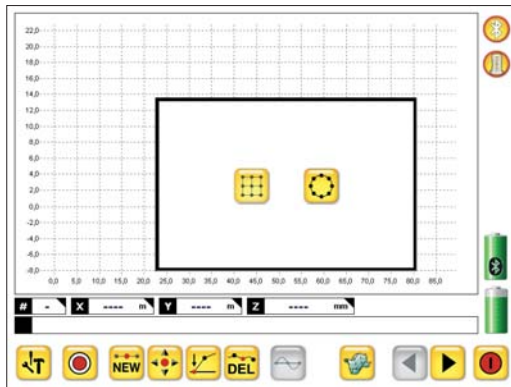

Select whether a rectangular surface or circles should be displayed. The selection refers to the first object to be measured.

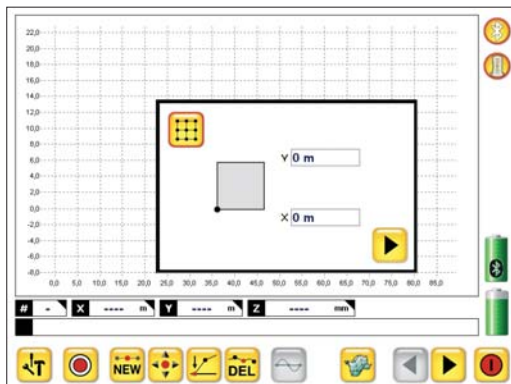

Determine the coordinate origin for the object to be measured. Normally the default value can be used here. Then click the “right” arrow to continue.

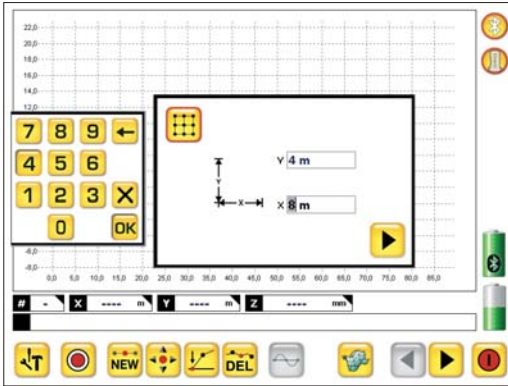

This screen is used to define the dimensions of the measuring grid.

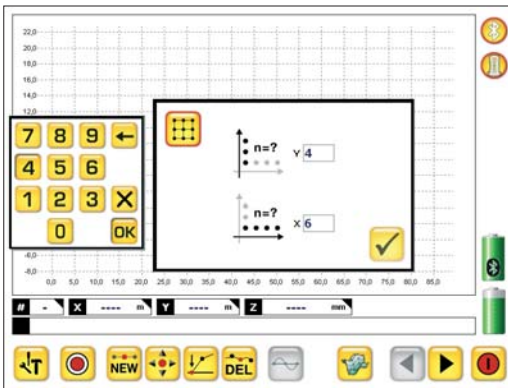

Here, the number of measuring points in the X and Y directions can be defined. If necessary, additional objects or measuring points can be added later.

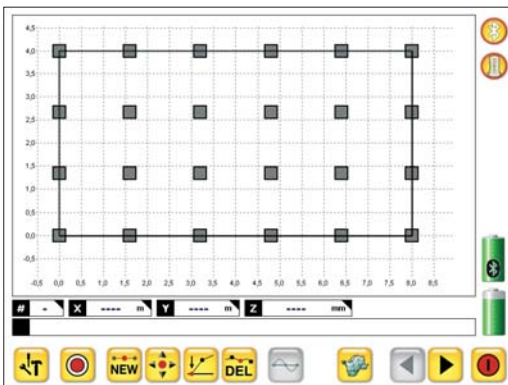

After entering the measuring points, the graphic with the measuring points is displayed. In this graphic the measuring points can be selected and measured by clicking them. Also, the graphic can be enlarged by pulling a window from the top left to the bottom right. Pulling the window from the bottom right to the top left restores it to the original size.

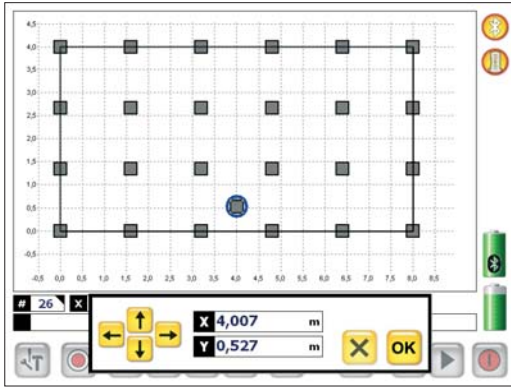

In the zoom-in view, the display can be moved in each direction by double clicking the graphic surface. This provides a good overview even when there are many measuring points. Alternatively, you can click the axis scale and enter the Min and Max values directly. Clicking the “NEW” button creates a new measuring point with a single click of the position in the graphic. In addition, a window opens where you can enter coordinates.

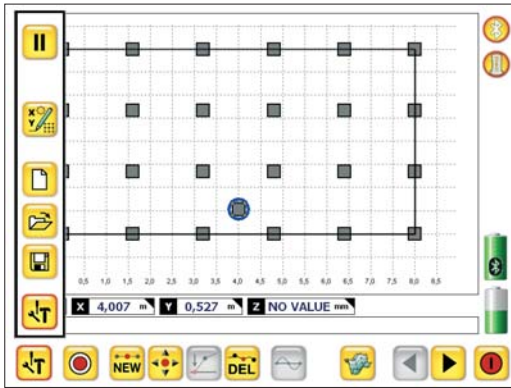

Selection of the menu
(Buttons from top to bottom):

- Pause
- Add new measuring point
- Start new measurement
- Get data from memory
- Save
- Toolbox

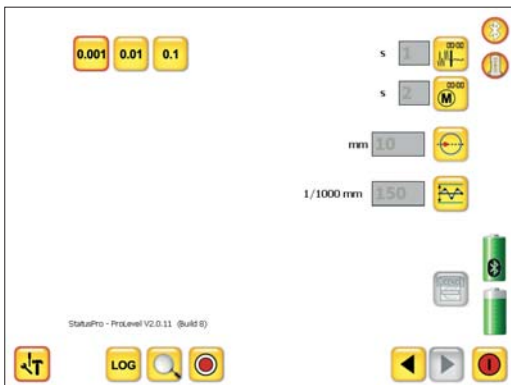

Menu of the toolbox
(Buttons from top to bottom):

- Displayed resolution
- Averaging time of the display
- Averaging time of the measuring pick-up
- Mean value for two measuring points
- Tolerance range

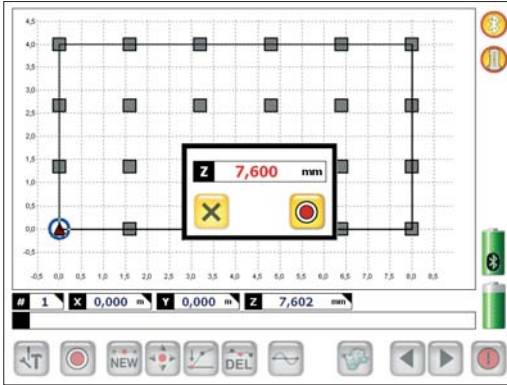



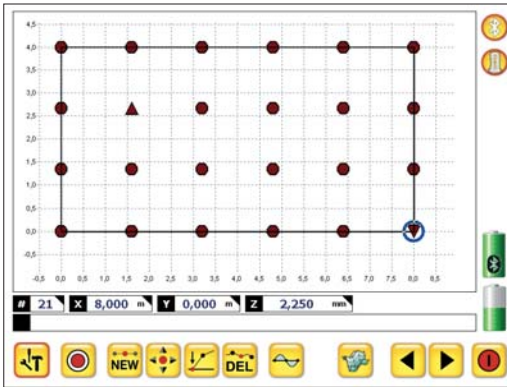

After placing the sensor and selecting the appropriate measuring point using the touch screen, in this case 0/0m (ft), the “measure button” can be pressed. Pressing the “measure button” displays the current measured value and pressing the  button saves the measurement.



After all points have been measured, the image shows all measuring points in an initial overview.

The symbols:

-  = point within the tolerance
-  = point too low – the darker and more intense, the lower the point
-  = point too high – the darker and more intense, the higher the point
-  = highest point  = lowest point

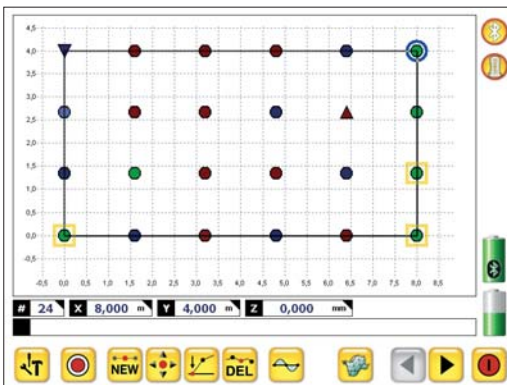

In any one axis, up to 2 measuring points can be zeroed, or a maximum of 3 points, to form a measurement plane. The deviation of all other points from this plane is displayed. If no point is zeroed, a compensation plane can be displayed .

If necessary, it is also possible to “zero” only one point and to activate the compensation plane. This plane then extends through the zeroed point.

Nr	X	Y	Z
1	0,000 m	0,000 m	7,602 mm
2	0,000 m	1,333 m	6,890 mm
3	0,000 m	2,667 m	7,690 mm
4	0,000 m	4,000 m	4,110 mm
5	1,600 m	0,000 m	5,280 mm
6	1,600 m	1,333 m	6,790 mm
7	1,600 m	2,667 m	9,250 mm
8	1,600 m	4,000 m	7,840 mm
9	3,200 m	0,000 m	6,030 mm
10	3,200 m	1,333 m	7,890 mm
11	3,200 m	2,667 m	7,950 mm
12	3,200 m	4,000 m	6,990 mm
13	4,800 m	0,000 m	3,370 mm
14	4,800 m	1,333 m	8,370 mm
15	4,800 m	2,667 m	2,367 mm
16	4,800 m	4,000 m	5,640 mm
17	6,400 m	0,000 m	3,900 mm
18	6,400 m	1,333 m	2,280 mm
19	6,400 m	2,667 m	9,250 mm
20	6,400 m	4,000 m	2,940 mm
21	8,000 m	0,000 m	2,250 mm
22	8,000 m	1,333 m	2,490 mm

Clicking the  button displays the measured data in a table.

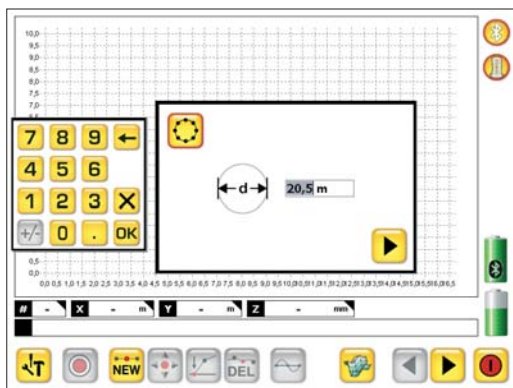

The software prompts the input of the circle diameter on which the measurement is to be carried out.

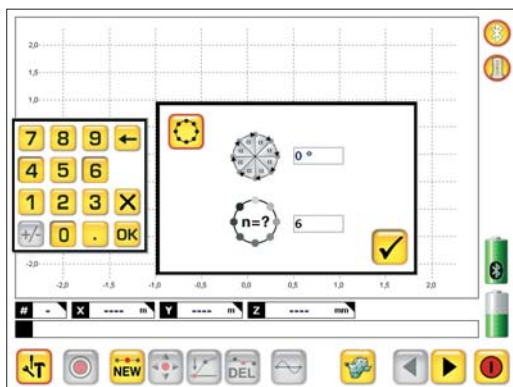

You can choose between two options for the input here:

- the angles at which a measurement is to be conducted on the circumference
- the number of measuring points on the circumference.

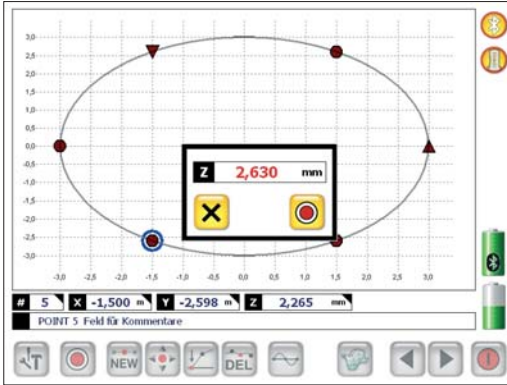

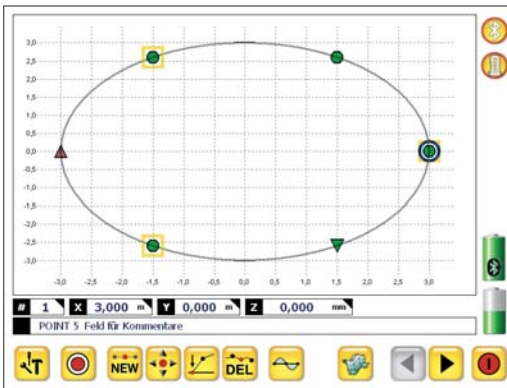

Afterwards, the circle is displayed and the measuring points can be selected and measured by clicking them.

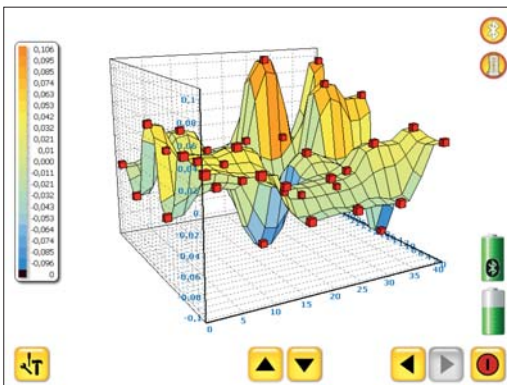

Up to 3 points can be zeroed to generate a plane.



Pressing the  button generates a 3D relief view of the measured values. The relief can be moved in any direction by holding down the mouse button. The   buttons are used to zoom in or out.

Register new sensors – license key

When you order a measuring package with a display unit from Status Pro, all components are ready to use when you receive them. If you wish to use your own computer or add additional sensors later, they have to be registered in the software in order to enable communication.







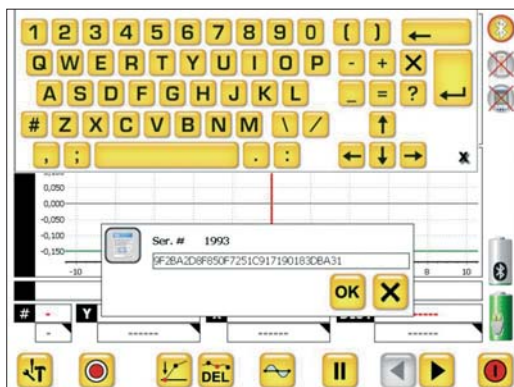























With your sensors, you receive a delivery note that includes a license key.

When you start ProLevel v2, the new sensor is found and the software prompts you to enter the license key.



Enter and confirm the license key that you received for the sensor. The unit is now ready for operation.

Description of program symbols

-  Record measuring point
-  Set new point
-  Move point,  zero,  delete
-  Compensating curve ("best fit")
– all deviations in +/- with same total
-  3D relief view
-  Previous / next page
-  Open / close settings
-  Create new measuring data file
-  Open measuring date file
-  Save results of measurement
-  Export results of measurements for reports
-  Set pause for current measured value display
-  Create additional measuring surfaces
-  Redefine rectangle or circle
-  x/y zero point rectangle / circle
-  Define size of measuring surface
-  Define number of measuring points in x and y direction
-  Define diameter of circle
-  Number of measuring points due to angle definition
-  Number of measuring points on circumference
-  Retrieve event log
-  Search for sensors
-  Definition of the displayed resolution
-  Define averaging time of the display
-  Define averaging time of the measuring pick-up
-  Define mean value for two measuring points
-  Define tolerance range
-  Bluetooth active / inactive
-  Sensors active / inactive / no connection
-  Charge condition of receiver / DU310
-  Enter sensor connection code (required only once for new sensors)
-  End program







DU310 UMPC



Part No. IT 200310

Operating system	Windows XP prof. (UMPC Edition), XP embedded or CE 5.0
Processor	AMD Geode LX800
Memory	512 MB - 1 GB RAM
Mass storage	512 MB - 8 GB Flash or 30 GB hard disk
Display	10.4" TFT, 1024x768, HiBrite
Touch Screen	Control with pen or finger
Interfaces	USB 2.0, CardBus PCMCIA Type II, CF-Card Slot, Bluetooth integrated, WLAN integrated, VGA
Security	Fingerprint reader, Intel WLAN Security
Rechargeable battery	Li-Ion 14 Wh internal, external extra battery 28 Wh replaceable or 74 Wh battery pack in carry bag
Housing	Magnesium/aluminum with rubber guard
Operating environment	Temperature 0–104 °F, relative humidity 0–90 % n.c.
Dimensions & weight	appr. 8.3x10.3x0.7 in, 2 lbs incl standard rechargeable battery
Special features	Front is splash & water proof, shock proof from as high as 4 feet (with rubber guard), 5 configurable keys, up to 4 hours of operation; Optional: multi-language, daylight display

Accessories for DU310 UMPC

Illustration	Part No.	Name
	IT 200202	Replacement control pen Quantity of 3 / package
	IT 200205	Rubber guard handle For holding the UMPC with one hand; is fastened on back on rubber guard
	IT 200206	Carrying strap for rubber guard handle Fastened on back on rubber guard
	IT 200207	External extra battery Li-Ion 28W Can be replaced during operation
	IT 200208	1-compartment charging station for external battery
	IT 200209	Car DC-DC converter 12V / 24V For connecting to docking station / car mounts or directly to the unit
	IT 200211	External expansion battery pack Li-ion 73Wh, charge level display



Part No. BG 830200/1

Rotation laser T310

The T310 leveling laser makes even difficult measuring tasks easy! A laser transmitter transmits the signal and a detector measures the beam position. Done!



Control of the T310

The control keys control various functions. In addition, LEDs function as displays.

1. IR-receiver with folding mirror
2. Leveling status -LED for Y-axis (or Z-axis in case of laying arrangement)
Green 1x: Leveling < 0.0016 in/ft;
2x: Leveling < 0.001 in/ft;
Red LED: Actuator motor working
3. Leveling status LED for X-axis
Green 1x: Leveling < 0.0016 in/ft;
2x: Leveling < 0.001 in/ft;
Red LED: Actuator motor working
4. Power status LED on / off
5. Power key on/off
6. Laser rotation on/off
7. Key cross for setting the laser level 5(+)/6(-)
As well as 3(+)/4(-)
8. Self-leveling on/off
9. Leveling status LED on/off
10. Level for rough leveling of the appliance

R310

The R310 measures the position of the rotating laser beam as a dial gauge from the work-piece for reference. The beam forms an entire reference plane and not just a line like a wire. The R310 is wireless and has a range of up to 80 m (262 ft).



Measuring range	80mm (3.15 in)
Resolution	0.01mm
Accuracy	+/- 0.02 + 0.3% linearity
IR control	Range: 50m (164 ft)
Interface	Rs232 / Bluetooth (optional)
Power supply	(rechargeable) battery 6x AA
Temperature range	0-50°C (0-122°F)

Part No. BG 830100

R525

20x20mm PSD,
without lens

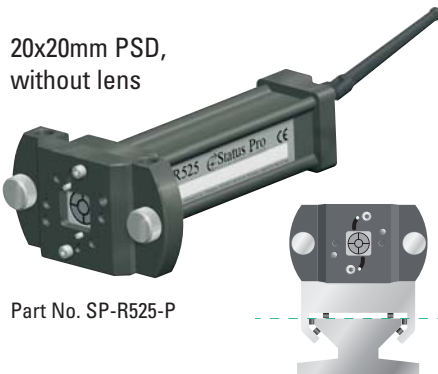

Part No. SP-R525-P

Measuring range	20x20mm
Resolution	1µm in X & Y
Accuracy	+/- 2µm
Inclinometer	Resolution 0,1°
Laser sensitivity	650nm / modulated
Wireless	Bluetooth class 1a (range: 30m (98 ft))
Interface	Rs232 / Bluetooth
Power supply	12V rechargeable battery
Operation with battery	8 hours
Charging time	2 hours – 90%
Protection class	IP 65



SEIFFERT 
INDUSTRIAL, INC. *Industrial Laser Alignment Systems*

Seiffert Industrial, Inc.
1323 Columbia Drive · Suite 305
Richardson, TX 75081
Phone: 972-671-9465
Fax: 972-671-9468
info@seiffertindustrial.com
www.seiffertindustrial.com



 **Status Pro**
m a s c h i n e n m e s s t e c h n i k

Status Pro Maschinenmesstechnik GmbH
Mausegatt 19
D-44866 Bochum
Phone: + 49 (0) 2327 - 9881 - 0
Fax: + 49 (0) 2327 - 9881 - 81
www.statuspro.com
info@statuspro.com

BA 1003E 06/08 · Design / DTP: Seichter & Steffens Grafikdesign, D-44229 Dortmund

Copyright 2008 Status Pro Maschinenmesstechnik GmbH. This user guide or parts thereof may not be copied or otherwise reproduced without explicit written from the management of Status Pro GmbH. The technical details are subject to change without notification. We would appreciate being informed of any errors in this manual.