

Fixturlaser Geometry

BORE MEASUREMENTS

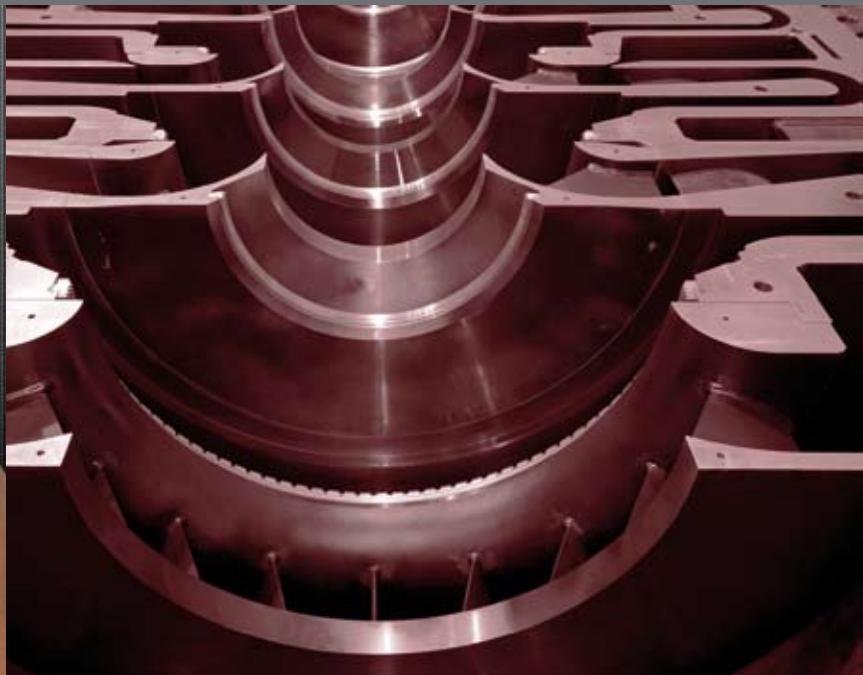

STRAIGHTNESS - BORE MEASUREMENTS

**Fixturlaser's laser based
geometry system**

is characterized by its user friendliness. An animated display screen combined with color coded values and icons result in a graphical user interface which is unequalled.

With live values, it will guide you throughout the geometry measurement and adjustment process.

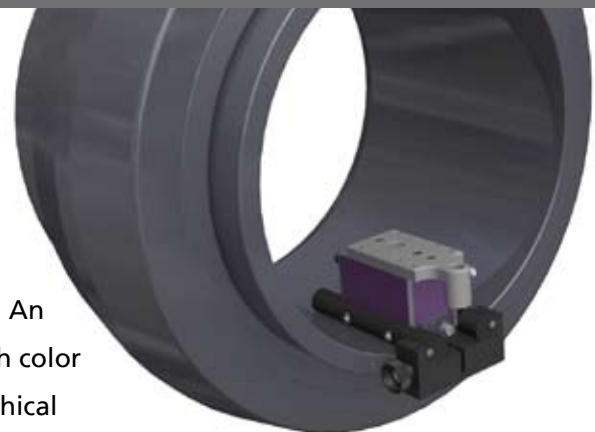

Geometric measurements by Fixturlaser



FIXTURLASER XA GEOMETRY

The Fixturlaser XA Geometry package shares many of the advanced technology components and functions with the much appreciated Fixturlaser XA shaft alignment system. The graphical user interface is icon based facilitating interpretation. It has the same animated color screen with color coded values and results, and the green arrows showing in which direction to move the machine or the measurement object.

The system is wireless for express data transfer; i.e. no cables between transmitters, detectors and the display box, so that you can move around in full freedom when recording measurement points or during adjustments. The documentation of measurement reports is handled via the USB ports for transfer to a PC or other storage media of your choice, i.e. no need for additional external software or hardware.



Clock Method



Arc Angle

The Fixturlaser XA Geometry system includes the following measurement methods:

- **straightness – standard, full bore, and half bore applications**
- **flatness – circular and flatness applications**

All three straightness measurement methods are available to you during the entire measurement process; e.g. if you start by measuring one point as full bore, you can choose to measure the next one as either standard straightness or as half bore.

EXPRESS GEOMETRY FUNCTIONS FOR YOUR BENEFIT



Best fit: You have the option to allow the system to calculate a reference line or plane, which illustrates the best fit, i.e. the least deviation for each measurement point in relation to the reference line or plane that has the least deviation of the measurement points.



The Touch and Release: The system gives you full freedom to record your measurements in any order you want. The touch and release function makes it easy to select the point to measure. Touch the screen, slide your finger across the display and release the finger at the point you want to measure. Together with the color screen and the graphical interface you can very quickly maneuver in your configuration even if many measuring points have to be registered.

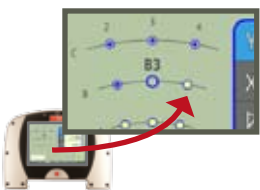

Express Navigation: When you select which points to measure, you will find that the highlighted measurement point is surrounded by its neighbor points enabling you to choose them without exiting the measurement point screen.



Use of Reference Receiver: With an additional receiver, you can use it as a reference receiver and zero it at the start of the measurement process. You are then able to control, without exiting the measurement screen, that the transmitter has not been moved during the actual measurement, which would cause incorrect measurement values.

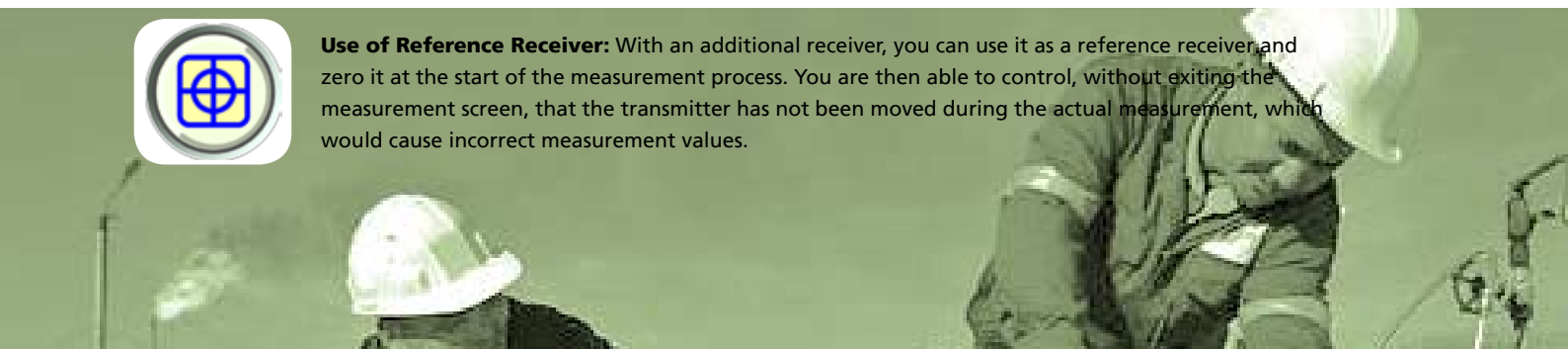

Bore Measurement

Straightness with the Clock Method



When measuring straightness with the clock method, you set the laser beam roughly parallel to a centre line.

Two points can be used as references. The program allows for up to 99 points to be measured.

Typical applications are full bore measurements, e.g. bearing journals for compressors and in diesel engines.



1. **express** Configuration

Quick and easy to configure

Pre-defined configuration



2. **express** Measurement

Distinct overall view of the measurement

Instant display of measurement object's position
Color coded measurement points

Measurement points can be registered in any order you prefer



3. **express** Adjustment

Live values during the adjustment phase

The angle guide displays the accepted (green) measurement point registration area

Green arrows show you in which direction to adjust towards zero.

Color coded measurement values

Straightness with the Arc Angle Method

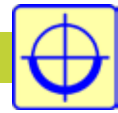

Straightness measurements with the Arc Angle method are made by setting the laser beam roughly parallel to a centre line.

Two points are used as references. The program allows for up to 99 points to be measured.

The sensor is placed in three to nine positions at each measurement point to find the centre of the measurement object. For the Arc Angle measurements the detector is in a single-axis mode.

Typical applications are half bore measurements, e.g. compressors and turbines with split casings.

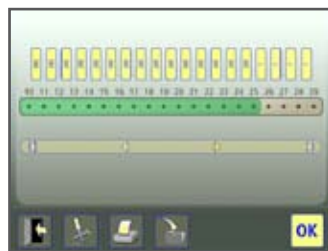
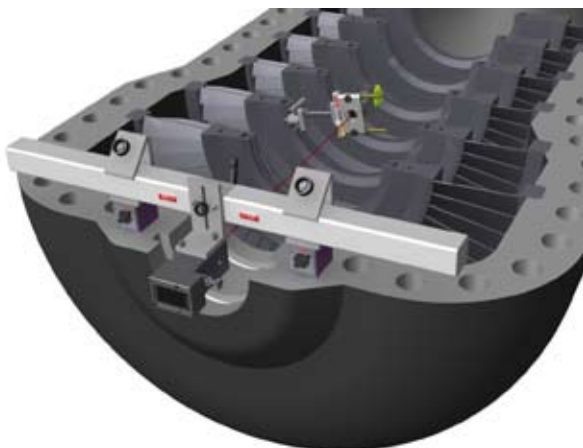

1. **express** Configuration

Quick and easy to configure

Pre-defined configuration



2. **express** Measurement

Distinct overall view of the measurement

Instant display of measurement results.

Color coded measurement points

Measurement points can be registered in any order you prefer



3. **express** Adjustment

Live values during the adjustment phase

The angle guide displays the accepted (green) measurement point registration area

Green arrows show you in which direction to adjust towards zero.

Color coded measurement values

Technical specification Fixturlaser XA Geometry

1-0832 Receiver Movable / 1-0833 Fixturlaser Receiver Stationary

Housing Material:	Anodized aluminium
Operating Temp:	0 to 50°C (32 to 122°F)
Storage Temp:	-20 to 70°C (-4 to 158°F)
Relative humidity:	10 – 90%
Weight:	110 g (3.9 oz)
Dimensions:	57 x 50 x 40 mm (2.2 x 2.0 x 1.6 in)
(with cable attached)	
Dimensions:	124 x 50 x 40 mm (4.9 x 2.0 x 1.6 in)
(with wireless transmitter 1-0835 attached)	
Environmental protection:	IP 65
Detector:	2-axis PSD
Detector size:	20 x 20 mm (0.8 x 0.8 in)
Detector resolution:	1 µm
Measurement accuracy:	1% ± 3 µm
Ambient light protection:	Optical filtering and ambient light signal rejection
Inclinometer resolution:	0.1°
Inclinometer accuracy:	±0.5

1-0835 Wireless Transmitter/Battery Pack BT2

Housing Material:	Anodized aluminium and PC/ABS plastic
Operating Temp:	0 to 50°C (32 to 122°F)
Storage Temp:	-20 to 70°C (-4 to 158°F)
Weight:	190 g (6.7oz) with batteries
Dimensions:	82 x 50 x 40 mm (3.2 x 2.0 x 1.6 in)
Wireless communication:	Class II Bluetooth transmitter
Communication range:	10 m (33 ft)
Power supply:	3 AA (LR6) batteries
Operating time:	10 hours continuously
LED indicators:	Transmitter and battery status indicators

Transmitter T110

Housing Material:	Anodized aluminium
Operating Temp:	0 to 50°C (32 to 122°F)
Storage Temp:	-20 to 70°C (-4 to 158°F)
Relative humidity:	10 – 90%
Weight:	1100 g
Dimensions:	60 x 60 x 140 mm (2.4 x 2.4 x 5.5 in)
Laser class:	Class 2
Measuring distance:	Up to 50 meters (164 feet)
Power supply:	2 batteries type LR6
Operating time:	15 hours continuously
Warming up time:	10 min



Display Unit 1-0753



Receiver Movable 1-0833
Receiver Stationary 1-0832



Wireless Transmitter 1-0835



Transmitter T110 1-0390



Fixturlaser's laser based shaft alignment and geometry systems are characterized by their user friendliness.

We pride ourselves in developing our products to be as easy to handle as possible, regardless of whether you use your alignment tool on a regular basis or just a few times a year.

We also value your time. Being user friendly also means being fast! With our systems' graphical user interface, you do not have to waste time on refreshing your memory or on second guessing yourself during the actual work; our user interface guides you throughout the entire measurement and adjustment or alignment process.